

# W104 - W105 - W106

**1000 - 2000 kg**

**W104**

**Gru idrauliche serie pesante,  
doppio effetto**

**Heavy duty workshop  
cranes, double acting**

**Grues hydrauliques série  
renforcée, double effet**

**Hydraulische Kräne,  
doppeltwirkend, schwere  
Serie**

**Grúas hidráulicas serie  
pesada, doble acción**

- Pompa a doppio effetto
- Valvola limitatrice di carico
- Comando tipo uomo presente
- Stelo cromato

- Double acting pump
- Overload safety-valve
- Dead man controls
- Chromium plated rod

- Pompe double effet
- Sécurité hydraulique en cas de surcharge
- Commande de type "homme mort"
- Tige chromée

- Doppeltwirkende Pumpe
- Überlastsicherung
- Totmann-Senkventil
- Verchromte Kolbenstange

- Bomba de doble acción
- Válvula limitadora de carga
- Mando de tipo hombre presente
- Vástago cromado

# WERTHER



# W104 - W105 - W106

**1000 - 2000 kg**

Dati tecnici - Technical data - Caractéristiques techniques - Technische Eigenschaften - Datos técnicos

	W104	W105	W106
A	1740	1850	2000
B	1500	1790	1970
C	1550	1840	1950
D	1250	1390	1500
E	165	195	220
F	525	470	530
G	720	750	810
H	2440	2860	2930
I	2650	3280	3280
L	900	1000	1150
M	1010	1150	1350
N	700	1140	1340
kg	130	220	300

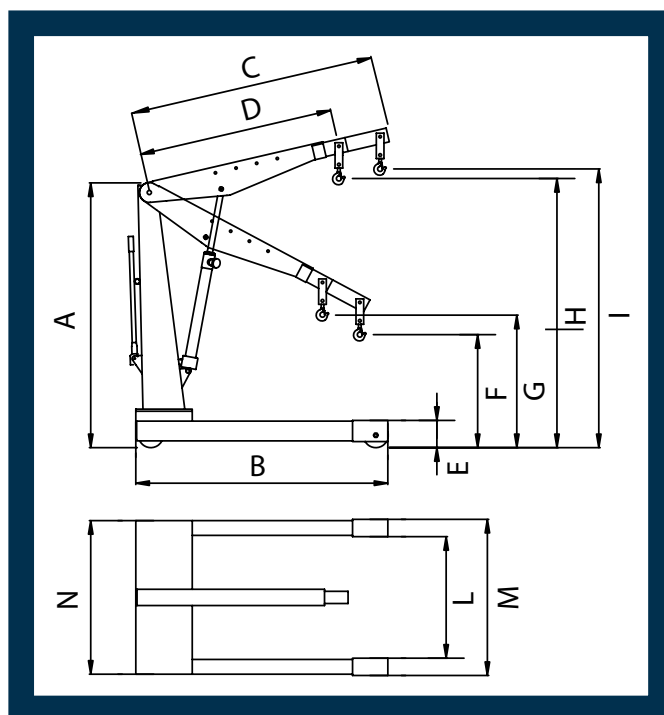

Kg	1	2	3	4
1	1000	1500	2000	
2	800	1200	1500	
3	500	800	1000	
4	300	500	600	

**WERATHER INTERNATIONAL S.p.A.**

Via F. Brunelleschi, 12 - 42124 Cadè (RE) Italy

Tel. ++39 0522 9431 - ++39 346 98 37 325 - ++39 346 98 37 443 - Fax ++39 0522 941997

www.wertherint.com - e-mail: sales@wertherint.com

Il fabbricante, nell'ambito del costante miglioramento dei propri prodotti, si riserva il diritto di apportare modifiche senza preavviso. - The company reserves the right to introduce improvements in design or specification without prior notice. - Der Hersteller behält sich das Recht vor, im Zuge der technischen Weiterentwicklung, technische Eigenschaften ohne Vorankündigung zu ändern. - Le fabricant dans le but d'améliorer constamment ses produits, se réserve le droit d'apporter des modifications sans préavis. - El fabricante, en el marco de la mejora constante de sus productos, se reserva el derecho de aportar modificaciones sin previo aviso.