



PR15



PR50

PR15

Pressa idraulica a colonna, 15 t
Hydraulic press, 15 t
Presse hydraulique, 15 t
Hydraulische Standpresse, 15 t
Prensa hidráulica de columna, 15 t

PR20

Pressa idraulica a colonna, 20 t
Hydraulic press, 20 t
Presse hydraulique, 20 t
Hydraulische Standpresse, 20 t
Prensa hidráulica de columna, 20 t

PR30

Pressa idraulica a colonna, 30 t con argano
Hydraulic press, 30 t with lifting winch
Presse hydraulique, 30 t avec treuil
Hydraulische Standpresse, 30 t mit Arbeitstisch-Hubwinde
Prensa hidráulica de columna, 30 t con cabrestante

PR50

Pressa idraulica a colonna, 50 t con argano
Hydraulic press, 50 t with lifting winch
Presse hydraulique, 50 t avec treuil
Hydraulische Standpresse, 50 t mit Arbeitstisch-Hubwinde
Prensa hidráulica de columna, 50 t con cabrestante

- Pompa a mano a due velocità
- Sicurezza idraulica in caso di sovraccarico
- Ritorno automatico del pistone
- Stelo cromato
- Manometro
- Serie di prismi a V

- Double-speed hand pump
- Overload safety-valve
- Automatic return of the ram
- Chromium plated rod
- Pressure gauge
- V-blocks

- Pompe manuelle double vitesse
- Sécurité hydraulique en cas de surcharge
- Retour automatique du piston
- Tige chromée
- Manomètre
- Jeu de prismes à V

- Zweistufige Handpumpe
- Überlastsicherung
- Automat. Kolbenrücklauf
- Verchromte Kolbenstange
- Manometer
- V-Prismensatz

- Bomba de mano con dos velocidades
- Seguridad hidráulica en caso de sobrecarga
- Retorno automático del pistón
- Vástago cromado
- Manómetro
- Serie de prismas en V

PR15 - PR20 - PR30 - PR50

15 - 50 t

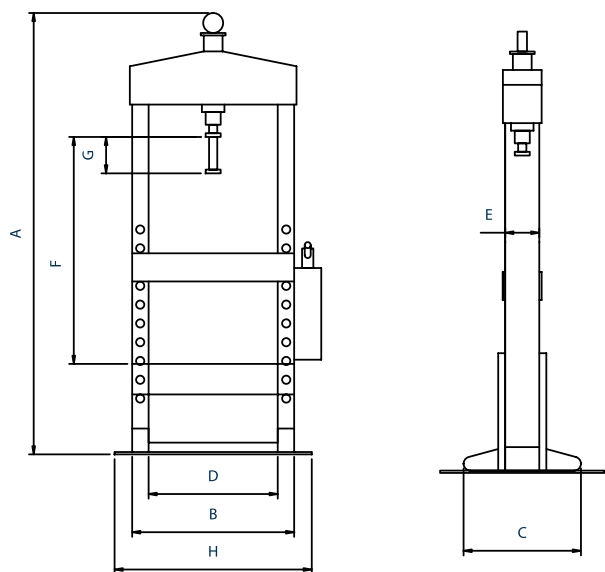

	PR15	PR20	PR30	PR50
A	1930	2030	2060	2290
B	730	800	900	985
C	650	650	650	650
D	550	620	700	785
E	170	180	200	210
F -	85	65	115	70
F +	950	1030	1020	1065
G	160	160	160	150
H	920	940	1120	1220
kg	150	165	230	370

Dati tecnici - Technical data - Caractéristiques techniques - Technische Eigenschaften - Datos técnicos

Opzioni - Optionals - Options - Sonderzubehör - Opciones

	PR15	PR20	PR30	PR50
Kit punzoni Plugs Kit de poinçons Stempelset Juego de punzones	T923 (15 t) Ø 29 24 18 14 10 5	T925 (20 t) Ø 29 24 18 14 10 5	T927 (30 t) Ø 29 24 18 14 10 5	T928 Ø 29 24 18 14 10 5
Piastra cacciaspine Press plate Plaque d'extraction Abdrückplatte Placa extractora de pasadores	T911 (15-20 t)	T911 (15-20 t)	T912 (30 t)	T913 (50 t)



PR15 - PR20

**WERTHER INTERNATIONAL S.p.A.**

Via F. Brunelleschi, 12 - 42124 Cadè (RE) Italy

Tel. ++39 0522 9431 - ++39 346 98 37 325 - ++39 346 98 37 443 - Fax ++39 0522 941997

www.wertherint.com - e-mail: sales@wertherint.com

Il fabbricante, nell'ambito del costante miglioramento dei propri prodotti, si riserva il diritto di apportare modifiche senza preavviso. - The company reserves the right to introduce improvements in design or specification without prior notice. - Der Hersteller behält sich das Recht vor, im Zuge der technischen Weiterentwicklung, technische Eigenschaften ohne Vorankündigung zu ändern. - Le fabricant dans le but d'améliorer constamment ses produits, se réserve le droit d'apporter des modifications sans préavis. - El fabricante, en el marco de la mejora constante de sus productos, se reserva el derecho de aportar modificaciones sin previo aviso.