





# 210I/32B 3,2 t | 210I/42B - 210I/42SMB 4,2 t



-  Sollevatore elettroidraulico a due colonne
-  Electro-hydraulic 2 post lift
-  Elektrohydraulische 2-Säulen-Hebebühne
-  Pont élévateur électrohydraulique à 2 colonnes
-  Elevador electro-hidráulico







210I/32B

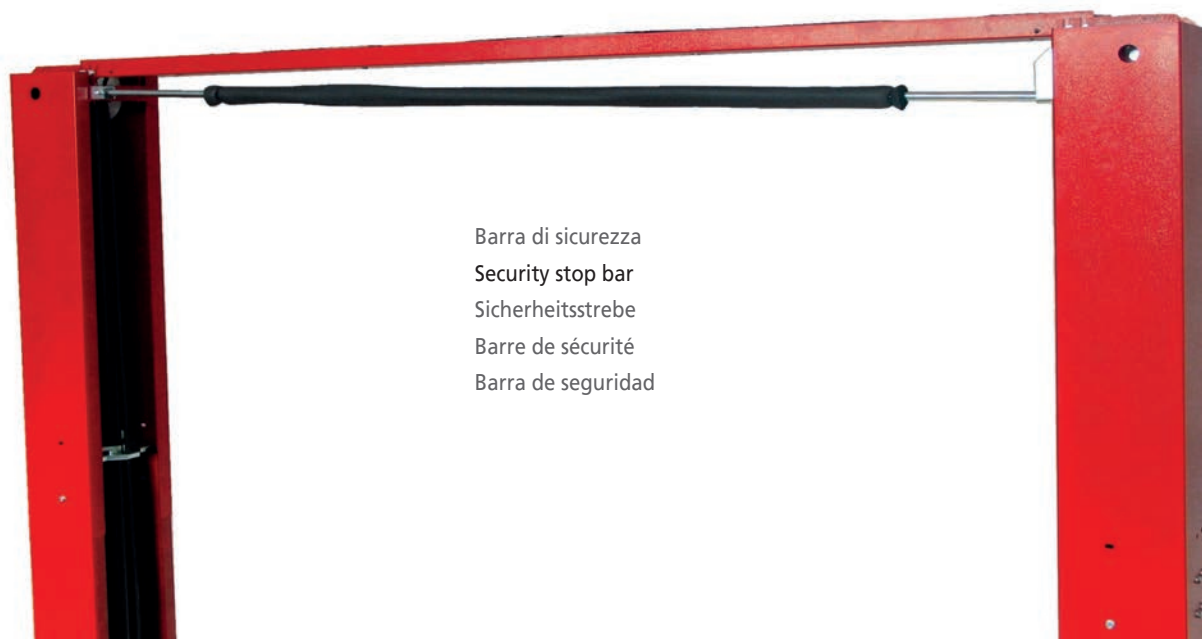

# 210I/32B 3,2 t | 210I/42B - 210I/42SMB 4,2 t



Barra di sicurezza  
Security stop bar  
Sicherheitsstrebe  
Barre de sécurité  
Barra de seguridad

-  Sollevatore asimmetrico senza base, permette la massima comodità nella zona di lavoro • Due cilindri di sollevamento che non richiedono alcuna manutenzione. I cavi non portanti garantiscono la perfetta sincronizzazione dei carrelli indipendentemente dalla ripartizione del carico • 210I-32B | 210I-42B: bracci corti a tre stadi super ribassati con profilo parallelo al pavimento per il sollevamento asimmetrico agevole anche di veicoli larghi e profilo basso. • 210I-42SMB: equipaggiato con 4 bracci lunghi a tre stadi, super ribassati con profilo parallelo al pavimento ideale per il sollevamento di furgoni e furgonati a passo lungo • Altezza minima tamponi di soli 95 mm • Valvole di sicurezza nei confronti di sovraccarichi e rottura di tubi idraulici • Valvola di controllo della velocità di discesa • Dispositivo di appoggio meccanico ad inserimento automatico e disinserimento manuale a garanzia della massima sicurezza in fase di stazionamento • Funzionamento: elettroidraulico
-  Symmetric lift without baseframe for greater space free area at work • Equipped with two lifting rams which do not require maintenance. Non-bearing cables for perfect synchronisation of the trolleys no matter what distribution weight is loaded • 210I-32B | 210I-42B: Designed with short, super lowered three-stage arms parallel to the floor: ideal for lifting low, long wheel based vehicles. • 210I-42SMB: designed with 4 extended three-stage arms: ideal for lifting vans and long wheel based vehicles • Pads min. height 95 mm. only • Safety valves protecting to prevent overloads and breakages of hydraulic hoses • Descent velocity controlled by hydraulic valve • Mechanical support device with automatic activation and deactivation by means of electro-magnetic valve insuring maximum safety during locking procedures • Operation: electro-hydraulic
-  Die grundrahmenfreie, asymmetrische Hebebühne gewährleistet eine bedienerfreundliche Handhabung im Arbeitsbereich • Wartungsfreie Hubzylinder. Die Gleichlaufkabel gewährleisten den einwandfreien Gleichlauf der Hubschleifen, unabhängig der Lastverteilung • 210I-32B | 210I-42B: ist ausgerüstet mit kurzen dreifach teleskopischen Armen, sehr niedrig und zwar die ganze Länge entlang paralleles Profil zum Boden für die asymmetrische Hebung von breiten und niedrigen Fahrzeugen. • 210I-42SMB: ist ausgerüstet mit 4 langen dreifach teleskopischen Armen, sehr niedrig und zwar die ganze Länge entlang paralleles Profil zum Boden • Aufnahmen mit einer Mindest-Unterschwenkhöhe von 95 mm • Ein Überdruckventil und eine Rohrbruchsicherung runden die Sicherheitsausstattung der Hebebühne ab • Hydraulisches Senkventil • Mechanische Fallsicherung die automatisch ein- und manuell ausrätet, gewährleistet die normkonforme Sicherheit beim Absetzen in die mechanische Fallsicherung • Funktionsweise: elektrohydraulisch
-  Elévateur symétrique sans base pour le meilleur confort dans la zone de travail • Les deux vérins de levage ne nécessitent d'aucun entretien. Les câbles non portants assurent la parfaite synchronisation des chariots quelque que soit la distribution du poids • 210I-32B | 210I-42B: équipé de 4 bras courts surbaissés avec profil parallèle au sol pour le levage asymétrique de véhicules larges et bas. • 210I-42SMB: équipé de 4 bras longs en trois parties: l'idéal pour le levage de fourgons et véhicules à long empattement, • Hauteur min. tampons de 95 mm seulement • Clapet de surpression en cas de surcharge et rupture de tuyaux hydrauliques • Clapet de limitation vitesse de descente • Dispositif d'appui mécanique à insertion automatique et désinsertion manuelle pour la mise en sécurité • Fonctionnement: électrohydraulique
-  Elevador asimétrico sin base, permite la máxima comodidad en la zona de trabajo • Dos cilindros de elevación que no requieren ningún mantenimiento, Los cables no portantes garantizan la perfecta sincronización de los carros independientemente de la repartición de la carga • 210I-32B | 210I-42B: Brazos cortos de tres estadios extra bajos con perfil paralelo al suelo para la elevación asimétrica también fácil de vehículos anchos y perfil bajo. • 210I-42SMB: equipado con 4 brazos largos de tres estadios, extra bajos con perfil paralelo al suelo ideal para la elevación de camionetas y furgones de paso largo • Altura mínima de los tacos de 95 mm • Válvulas de seguridad de sobrecargas y rotura de tubos hidráulicos • Válvula de control de la velocidad de descenso • Dispositivo de apoyo mecánico de activación automática y desactivación manual como garantía de la máxima seguridad en fase de estacionamiento • Funcionamiento: electro-hidráulico

# 210I/32B 3,2 t | 210I/42B - 210I/42SMB 4,2 t



Arresto bracci a inserimento automatico e sgancio automatico a terra

Automatic locking & unlocking of arms during on floor

Schwenkarmarretierung rastet automatisch ein (in der unteren Nullstellung) und aus (beim Heben aus der Nullstellung)

Arrêt des bras à insertion automatique et désinsertion automatique à terre

Parada de brazos de activación automática y desenganche automático de tierra



Comando a uomo presente, 24V

Dead man controls, 24V

24V - Totman-Schaltung

Commande "homme mort", 24V

Mandos de hombre presente, 24V

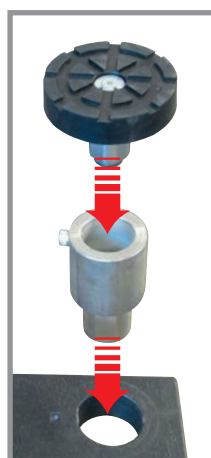

Bracci predisposti per l'alloggiamento rapido di prolungha

Arms suitable for quick drop-in extensions

Aufnahmen mit Schnellstecksystem erleichtern den Einsatz von Verlängerungen.

Bras prévus pour le montage rapide de rallonges

Brazos predispuestos para el alojamiento rápido de suplementos.



Opzioni



Optionals



Sonderzubehör



Options



Opcionales

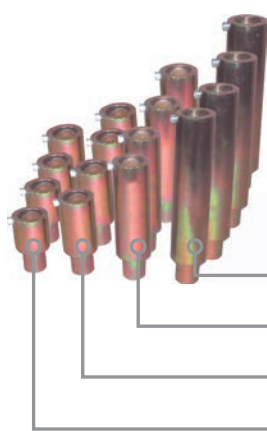

Estensioni per tamponi (kit 4 pz)

Lifting pad extensions (4 pcs set)

Hubspindelverlängerungen (Satz 4 Stk)

Rallonges pour tampons (jeu de 4 pcs)

Extensiones para tacos (kit 4 un.)

250 mm (L955)

170 mm (L954)

100 mm (L953)

60 mm (L956)



Esecuzione con motore monofase

Single-phase motor

Moteur monophasé

Ausführung mit Einphasenmotor

Motor monofásico

# 210I/32B 3,2 t | 210I/42B - 210I/42SMB 4,2 t

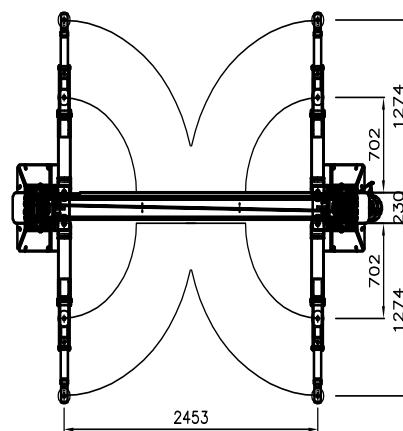
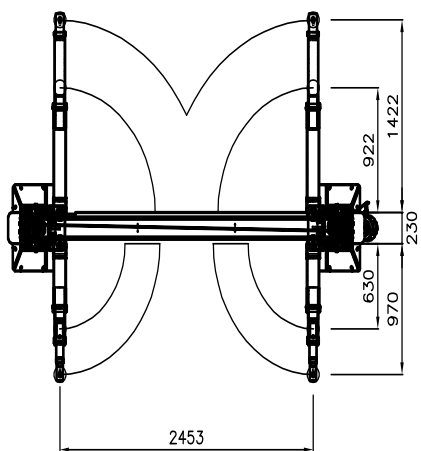
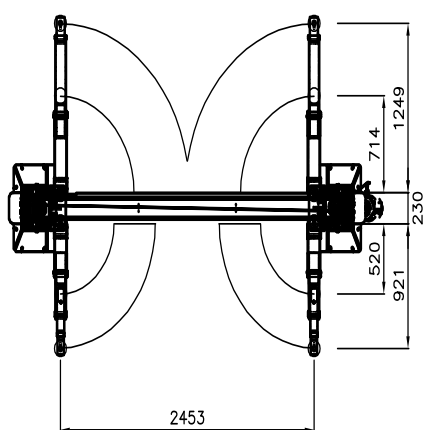
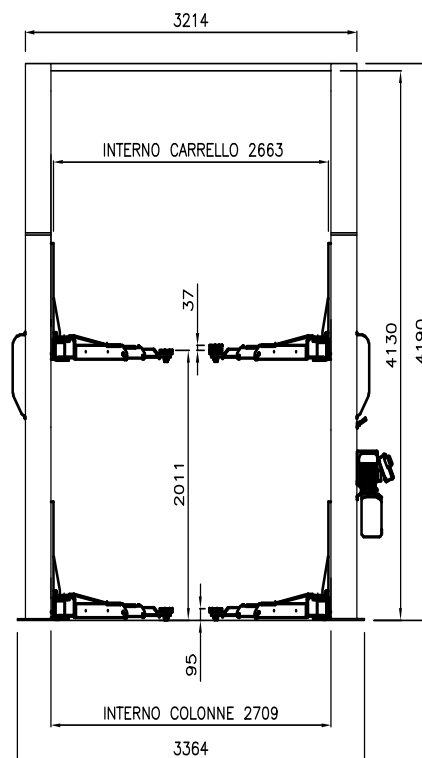
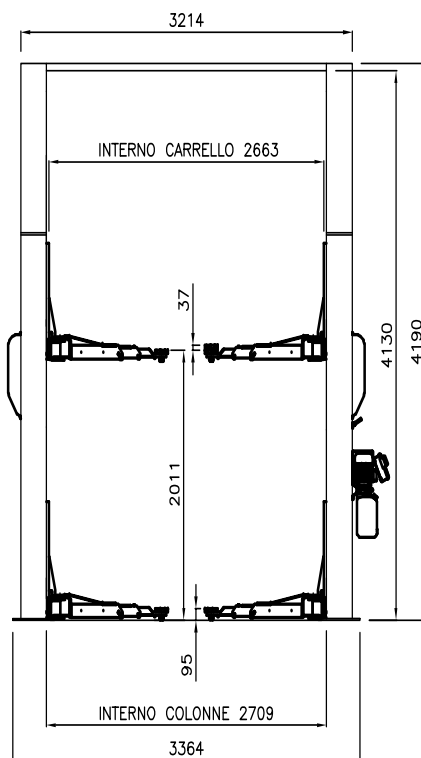
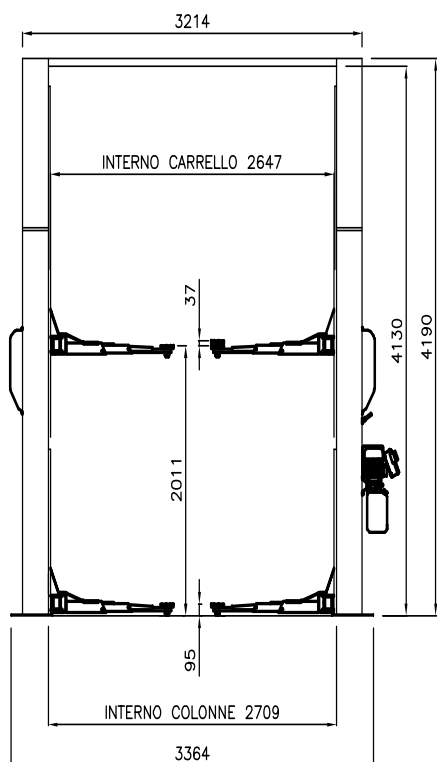

210I/32B

210I/42B

210I/42SMB



Dati tecnici	Technical data	Technische Eigenschaften	Caractéristiques techniques	Datos técnicos	210I/32	210I/42B	210I/42SMB
Portata	Capacity	Tragfähigkeit	Capacité	Capacidad	3.200 kg	4.200 kg	4200 kg
Peso	Weight	Gewicht	Poids	Peso	690 kg	715 kg	745 kg
Salita/Discesa	Lifting/lowering	Hub/Senkzeit	Levage/descente	Subida/bajada	37/37 s	43/43 s	43/43 s
Altezza di sollevamento	Lifting height	Hubhöhe	Hauteur de levage	Altura de elevación	2011mm		
Motore	Motor	Motorleistung	Puissance moteur	Motor	2,2 kW - 230-400 V/50 Hz 3 ph		