





# 232I 3,2 t | 232IH 3,2 t



-  Sollevatore elettroidraulico a due colonne
-  Electro-hydraulic 2 post lift
-  Elektrohydraulische 2-Säulen-Hebebühne
-  Pont élévateur électrohydraulique à 2 colonnes
-  Elevador electro-hidráulico



Comando a uomo presente, 24V  
 Dead man controls, 24V  
 Totman-Schaltung 24V  
 Commande "homme mort", 24V  
 Mandos de hombre presente, 24V



Dispositivo di appoggio meccanico ad inserimento automatico e disinserimento elettromagnetico a garanzia della massima sicurezza in fase di stazionamento

Mechanical support device with automatic activation and deactivation by means of electro-magnetic valve insuring maximum safety during locking procedures

Mechanische Fallsicherung die automatisch ein- und ausrastet, gewährleistet die normkonforme Sicherheit beim Absetzen in die mechanische Fallsicherung

Dispositif d'appui mécanique à insertion automatique et désinsertion électro-magnétique pour la mise en sécurité

Dispositivo de apoyo mecánico de activación automática y desactivación electromagnética como garantía de la máxima seguridad en fase de estacionamiento

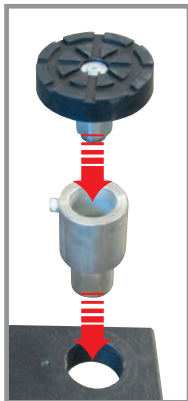

Bracci predisposti per l'alloggiamento rapido di prolunghe

Arms suitable for quick drop-in extensions

Aufnahmen mit Schnellstecksystem erleichtern den Einsatz von Verlängerungen.

Bras prévus pour le montage rapide de rallonges

Brazos predisuestos para el alojamiento rápido de suplementos.



Arresto bracci a inserimento automatico e sgancio automatico a terra

Automatic locking & unlocking of arms during on floor

Schwenkarmarretierung rastet automatisch ein (in der unteren Nullstellung) und aus (beim Heben aus der Nullstellung)

Arrêt des bras à insertion automatique et désinsertion automatique à terre

Parada de brazos de activación automática y desenganche automático de tierra

Apertura fra colonne 2.650 mm – altezza minima tamponi di soli 95 mm – bracci corti e lunghi a tre stadi, più corti in posizione chiusura per facilitare il caricamento asimmetrico di veicoli larghi e più lunghi in posizione estesa - raccomandati per il sollevamento di fuoristrada • Notevoli possibilità di regolazione dei bracci per facilitare il carico asimmetrico e la comoda apertura delle portiere • Due cilindri di sollevamento che non richiedono alcuna manutenzione. I cavi non portanti garantiscono la perfetta sincronizzazione dei carrelli indipendentemente dalla ripartizione del carico • Valvole di sicurezza nei confronti di sovraccarichi e rottura di tubi idraulici • Valvola di controllo della velocità di discesa • Funzionamento: elettroidraulico

2,65 mt span between posts • Super low 95 mm. Pads • Well designed asymmetric 3 stage arms, ideal for easy undercarriage access when retracted, and perfect for long & wide vehicles when extended • Ultimate use with 4 wheel drives • Adjustable arms for easier asymmetric loading and door opening • Two lifting rams with transmission to the opposite post by means of steel rope. Non-bearing cables granting perfect synchronisation of carriages no matter what distribution weight is loaded • Safety valves protecting to prevent overloads and breakages of hydraulic hoses • Descent velocity controlled by hydraulic valve • Operation: electro-hydraulic

Säulenabstand 2650 mm -Mindestaufnahmehöhe 95 mm -Dreifach teleskopierbare kurze und lange Arme ermöglichen in geschlossener Stellung die asymmetrische Aufnahme von breiten Fahrzeugen - in ausgezogener Stellung können extra-lange Fahrzeuge aufgenommen werden - besonders geeignet zum Heben von Off-Road-Fahrzeugen • Besonders vielseitige Einstellungsmöglichkeiten der Arme gewährleisten asymmetrische Fahrzeugaufnahme und bequeme Türöffnung • Beide Hubzylinder brauchen keine Wartung. Die Gleichlaufkabel gewährleisten den einwandfreien Gleichlauf der Hubschlitzen, unabhängig der Lastverteilung • Ein Überdruckventil und eine Rohrbruchsicherung runden die Sicherheitsausstattung der Hebebühne ab • Hydraulisches Senkventil • Funktionsweise: elektrohydraulisch

Écartement entre colonnes 2650 mm – hauteur min. tampons de 95 mm seulement – bras courts et longs en trois parties, plus courts en position fermeture pour faciliter le chargement asymétrique de véhicules larges et plus longs en position étendue – recommandés pour le levage de véhicules tout-terrain • Possibilité de régler les bras pour faciliter le chargement asymétrique et l'ouverture des portes • Les deux vérins de levage ne nécessitent d'aucun entretien. Les câbles non portants assurent la synchronisation parfaite des chariots quelque que soit la distribution du poids • Clapet de surpression en cas de surcharge et rupture de tuyaux hydrauliques • Clapet de limitation vitesse de descente • Fonctionnement: électrohydraulique

Apertura entre columnas 2650 mm - altura mínima de los tacos 95 mm – brazos cortos y largos de tres estadios, más cortos en posición cerrada para facilitar la carga asimétrica de vehículos anchos y más largos en posición extendida - recomendados para la elevación de vehículos todo terreno • Notables posibilidades de regulación de los brazos para facilitar la carga asimétrica y la cómoda apertura de las puertas • Dos cilindros de elevación que no requieren ningún mantenimiento. Los cables no portantes garantizan la perfecta sincronización de los carros independientemente de la repartición de la carga • Válvulas de seguridad de sobrecargas y rotura de tubos hidráulicos • Válvula de control de la velocidad de descenso • Funcionamiento: electro-hidráulico

# 232I 3,2 t | 232IH 3,2 t

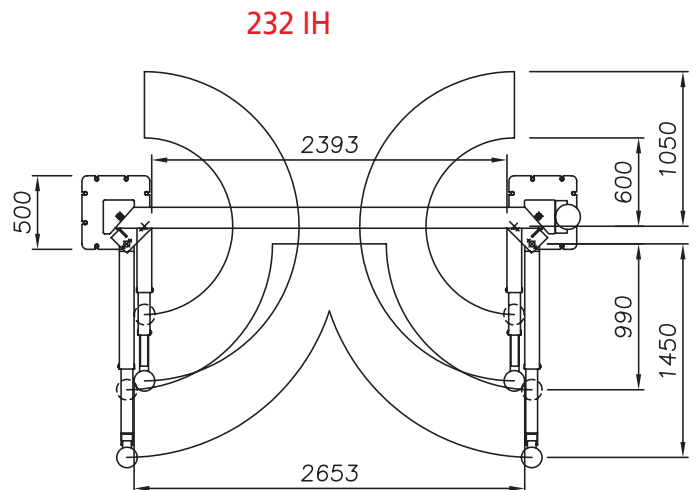
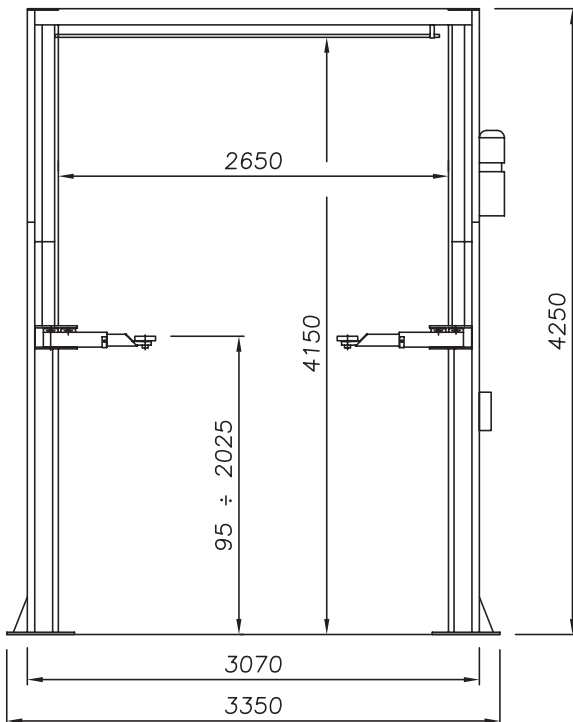
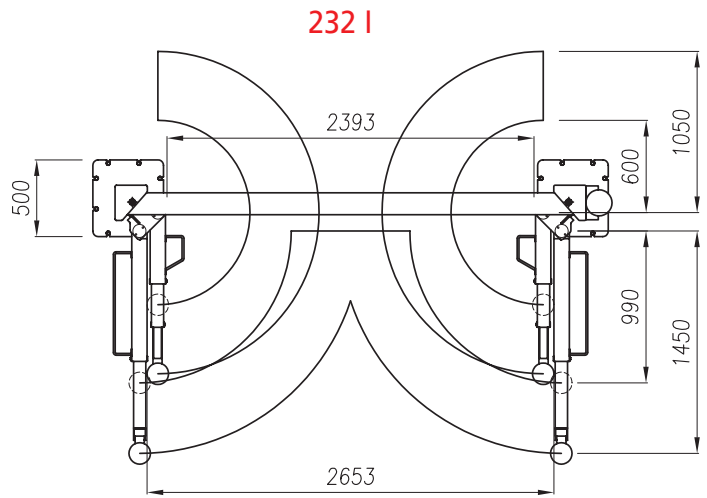
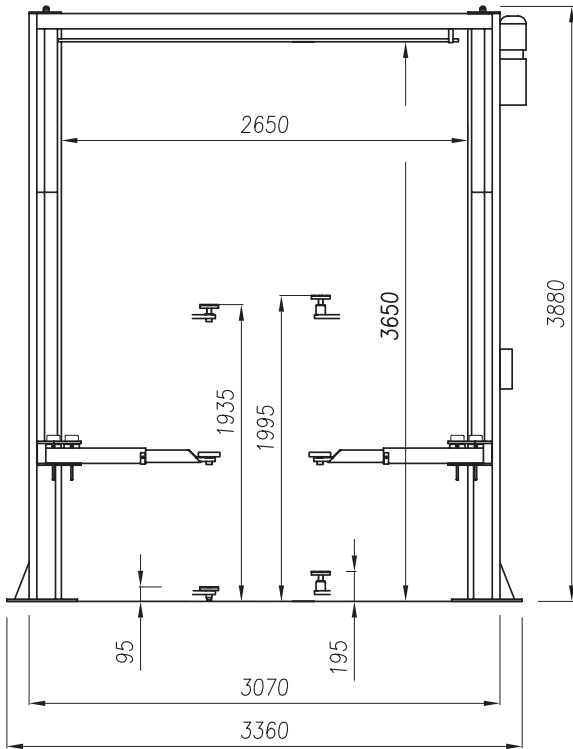

# 232I 3,2 t | 232IH 3,2 t



Dati tecnici	Technical data	Technische Eigenschaften	Caractéristiques techniques	Datos técnicos	232I	232IH
Portata	Capacity	Tragfähigkeit	Capacité	Capacidad		3.200 kg
Peso	Weight	Gewicht	Poids	Peso	700 kg	750 kg
Salita/Discesa	Lifting/lowering	Hub/Senkzeit	Levage/descente	Subida/bajada	45 s	30 s
Altezza di sollevamento	Lifting height	Hubhöhe	Hauteur de levage	Altura de elevación	1935 mm	2025 mm
Motore	Motor	Motorleistung	Puissance moteur	Motor	2,2 kW - 3 ph 230-400V/50 Hz	



Opzioni	Optionals	Sonderzubehör	Options	Opcionales
---------	-----------	---------------	---------	------------

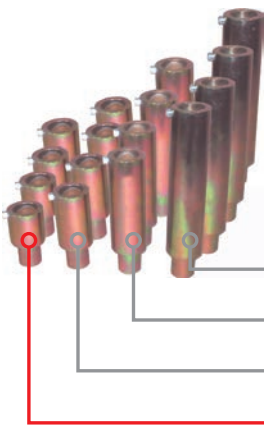

Estensioni per tamponi (kit 4 pz)  
 Lifting pad extensions (4 pcs set)  
 Hubspindelverlängerungen (Satz 4 Stk)  
 Rallonges pour tampons (jeu de 4 pcs)  
 Extensiones para tacos (kit 4 un.)

- 250 mm (L955)
- 170 mm (L954)
- 100 mm (L953)
- 60 mm (L956 standard included)

Esecuzione con motore monofase

Single-phase motor

Moteur monophasé

Ausführung mit Einphasenmotor

Motor monofásico



Tamponi click system  
 Click system pads  
 Tragteller mit Click System  
 Tampons de levage click system  
 Tacos click system

