





300S 3,0 t | 300SEV 3,0 t



-  Sollevatore a due colonne senza base
-  Two post lift without baseframe
-  Zweisäulenhebebühne ohne Grundrahmen
-  Elévateur a deux colonnes sans base
-  Elevador a dos columnas sin base



300S 3,0 t | 300SEV 3,0 t



Motore speciale ad alto rendimento per garantire potenza e durata nel tempo, dotato di sonda termica di protezione

Specially manufactured motor fitted with overheating & overload protection switch

Spezieller Hochleistungsmotor mit Thermoschutz liefert üppig bemessene Antriebsleistung und gewährleistet lange Lebensdauer

Moteur spécial à haute performance pour garantir puissance et durée dans le temps, équipé de sonde thermique de protection

Motor especial de alto rendimiento para garantizar potencia y duración en el tiempo, suministrado con termico de protección

Vite rullata in acciaio ad alta resistenza per garantire la massima durata nel tempo

Steel high resistance rolled screw to provide long life

Kaltgewaltze Spindel aus gehärtetem Stahl für eine lange Lebensdauer

Vis en acier, roulée, à haute résistance, pour garantir la durée dans le temps

Husillo de acero de alta resistencia, rosca fabricada en frío con rodillos para garantizar la máxima duración en el tiempo



Chiocciola portante in Nylatron GSM ad elevata resistenza all'usura a garanzia di sicurezza totale

Nylatron GSM main nut with high resistance to wear for greater safety

Verschleissfeste Tragmutter aus Nylatron GSM für eine totale Sicherheit

Ecrou porteur en Nylatron GSM à haute résistance à l'usure pour garantir une sécurité totale

Tuerca principal en Nylatron GSM de alta resistencia al desgaste para garantizar la seguridad total

 Sollevatore con sincronizzazione elettronica senza base, permette la massima comodità di movimento nella zona di lavoro. Possibilità di installazione dei cavi di collegamento al soffitto o incassati nel pavimento • La sincronizzazione elettronica fra i carrelli mantiene il dislivello entro un massimo di 24 mm • Due motori speciali ad alto rendimento per garantire potenza e durata nel tempo, dotati di sonda termica di protezione • Comandi in bassa tensione • Bracci corti e bracci lunghi a tre stadi per il sollevamento asimmetrico di furgoni e fuoristrada • Bracci super-ribassati, con profilo parallelo al pavimento • Tamponi con altezza minima di soli 95 mm • Lubrificazione permanente e automatica della vite • Funzionamento: elettromeccanico

 Lift with electronic synchronisation without baseframe for easy movement in the working area. The connecting cables can be fixed to the ceiling or recessed into the floor • Electronic synchronisation between carriages to keep the height difference within max 24 mm • Two specially manufactured high performing motors to provide long life; fitted with protecting thermic sensor • Low voltage controls • Short and long three-stage arms for the asymmetric lifting of vans and 4-wheel drive vehicles • Super lowered arms parallel to the floor • Pads min. height 95 mm. only • Permanent and automatic screw lubrication • Operation: electro-mechanical

 Hebebühne mit elektronischer Gleichlaufsteuerung ohne Grundrahmen für die einfachste Bedienung in der Arbeitszone. Die Verbindungskabel können sowohl über die Decke oder im Boden verlegt werden • Die elektronische Gleichlaufsteuerung regelt den Gleichlauf der Hubschleitten und beschränkt den Ungleichlauf auf max. 24 mm • Zwei spezielle Hochleistungsmotoren mit Thermoschutz liefern üppig bemessene Antriebsleistung und gewährleisten lange Lebensdauer • Bedienungselemente liegen alle an Niederspannung (24 Volt) • Dreifach teleskopische lange und kurze Arme, um die problemlose asymmetrische Aufnahme von Lieferwagen und 'Off-Road'-Fahrzeugen zu gewährleisten • Sehr niedrige Arme • Aufnahmen mit einer Mindest-Unterschwenkhöhe von 95mm • Automatische Dauerschmierung der Spindel • Funktionsweise: elektromechanisch

 Elévateur avec synchronisation électronique sans base, facilitant le mouvement dans la zone de travail. Installation des câbles de connexion au plafond ou encastrés au sol • La synchronisation électronique entre les chariots limite la dénivellation à un écart max de 24 mm • Deux moteurs spéciaux à haute performance garantissent puissance et durée dans le temps; équipés de sonde thermique de protection • Commandes à bas voltage • Bras courts et bras longs en trois parties pour le levage asymétrique de fourgons et toutterrains • Bras super-baïssés avec profil parallèle au sol • Tampons de hauteur min. de 95 mm seulement • Lubrification permanente et automatique de la vis • Fonctionnement: électro-mécanique

 Elevador con sincronización electrónica sin base: permite un fácil acceso al área de trabajo. Posibilidad de instalación de los cables en el techo o empotrados en el suelo • La sincronización electrónica entre los carritos permite mantener un plazo máximo de desnivelación de 24 mm • Dos motores distintos y de alta eficiencia para asegurar potencia y duración en el tiempo, ambos con sonda térmica de seguridad • Controles a bajo voltaje • Brazos cortos y largos a tres etapas para levantamiento asimétrico de furgonetas y vehículos de todoterrenos • Brazos extra rebajados con perfil paralelo al suelo • Tampones con altura máxima de sólo 95mm • Lubricación permanente y automática del tornillo • Funcionamiento: electro-mecánico

300S 3,0 t | 300SEV 3,0 t



Arresto bracci a inserimento automatico e sgancio automatico a terra

Automatic locking & unlocking of arms during on floor

Schwenkarmarretierung rastet automatisch ein (in der unteren Nullstellung) und aus (beim Heben aus der Nullstellung)

Arrêt des bras à insertion automatique et désinsertion automatique à terre

Parada de brazos de activación automática y desenganche automático de tierra



Comando a uomo presente, 24V

Dead man controls, 24V

24V - Totman-Schaltung

Commande "homme mort", 24V

Mandos de hombre presente, 24V

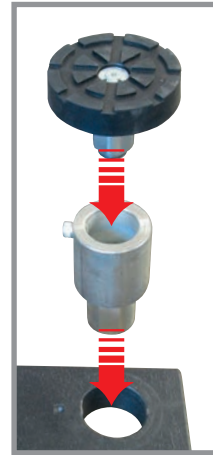

Bracci predisposti per l'alloggiamento rapido di prolunghe

Arms suitable for quick drop-in extensions

Aufnahmen mit Schnellstecksystem erleichtern den Einsatz von Verlängerungen.

Bras prévus pour le montage rapide de rallonges

Brazos predispuestos para el alojamiento rápido de suplementos.



Opzioni



Optionals



Sonderzubehör



Options



Opcionales

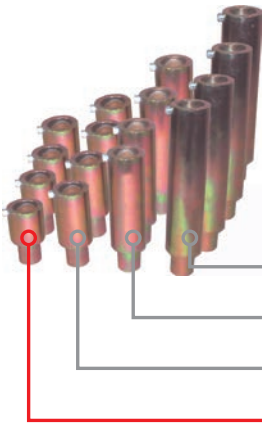

Estensioni per tamponi (kit 4 pz)

Lifting pad extensions (4 pcs set)

Hubspindelverlängerungen (Satz 4 Stk)

Rallonges pour tampons (jeu de 4 pcs)

Extensiones para tacos (kit 4 un.)

250 mm (L955)

170 mm (L954)

100 mm (L953)

60 mm (L956 standard included)



Kit energy: supporto attrezzi e prese aria e corrente

Kit energy: tool support, air connection and electric power plug

Kit Energy: Werkzeughalter, Lu tanschluss und Steckdose

Kit énergie: support outils, prises d'air et de courant

Kit energy: soporte herramientas y conexiones de aire y de corriente

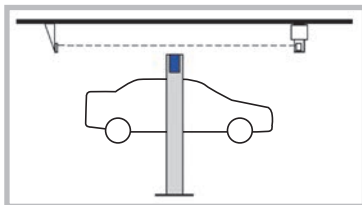

Kit fotocellula a soffitto

Ceiling fitted cut-off sensor

Hubenschalter zur Installation unter Decke

Capteur fin de course installé au plafond

Kit fotocélula instalada en el techo



Tamponi click system

Click system pads

Trageller mit Click System

Tampons de levage click system

Tacos click system

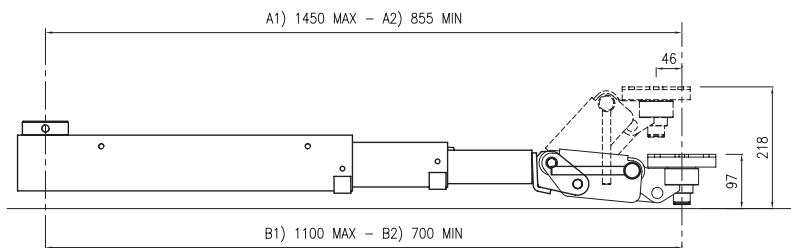
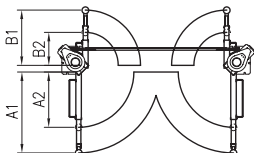

300S 3,0 t | 300SEV 3,0 t

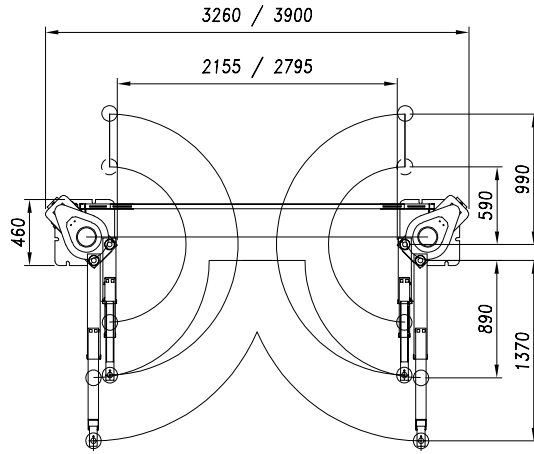
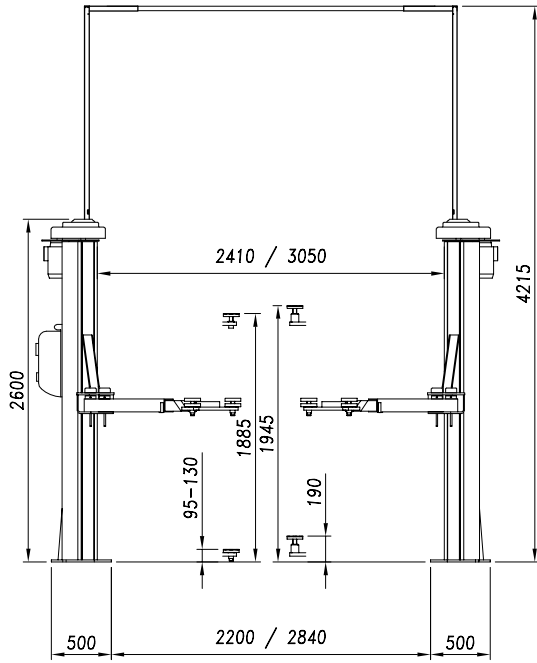

300S

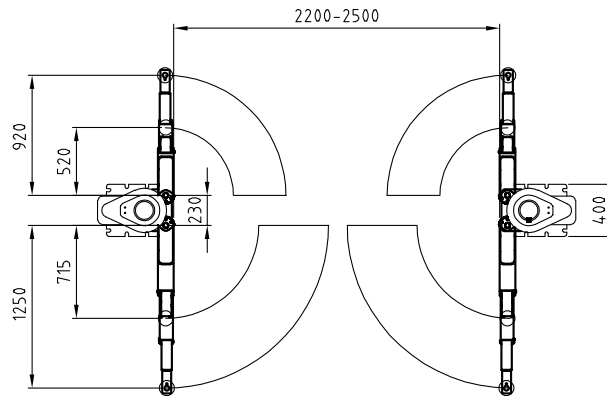
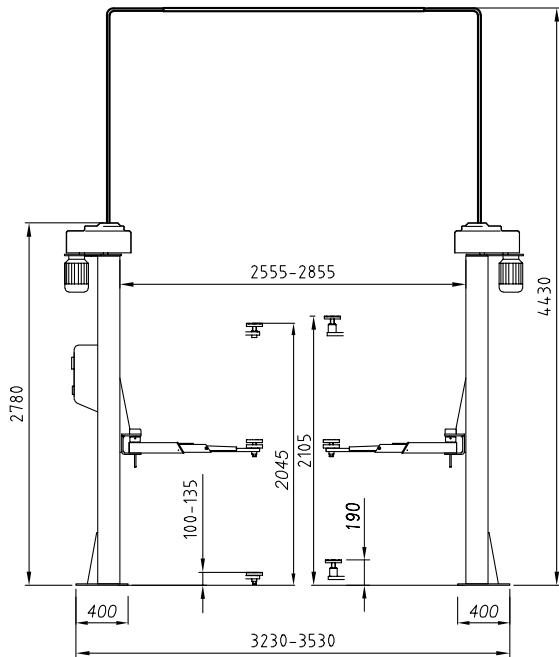

Rev3 09-10-19

300SEV



Dati tecnici	Technical data	Technische Eigenschaften	Caractéristiques techniques	Datos técnicos	300S	300SEV
Portata	Capacity	Tragfähigkeit	Capacité	Capacidad	3.000 kg	3.000 kg
Peso	Weight	Gewicht	Poids	Peso	600 kg	530 kg
Salita/Discesa	Lifting/lowering	Hub/Senkzeit	Levage/descente	Subida/bajada	65 s (52 s high speed optional)	55 s
Altezza di sollevamento	Lifting height	Hubhöhe	Hauteur de levage	Altura de elevación	1885 mm	2045 mm
Motore	Motor	Motorleistung	Puissance moteur	Motor	2 x 2,6 kW - 3 ph 230-400V/50 Hz	