













J2P

-  Cric pneumatico portatile a 2 stadi
-  **Pneumatic 2-stage jack**
-  Pneumatischer Wagenheber mit 2 Stufen
-  Cric pneumatique à 2 étages
-  Gato neumático portátil de 2 etapas







J3P





-  Cric pneumatico portatile a 3 stadi
-  **Pneumatic 3-stage jack**
-  Pneumatischer Wagenheber mit 3 Stufen
-  Cric pneumatique à 3 étages
-  Gato neumático portátil de 3 etapas



J2C

-  Cric pneumatico portatile a 2 stadi con carrello
-  **Pneumatic 2-stage jack with trolley**
-  Pneumatischer Wagenheber mit 2 Stufen, mit Wagen
-  Cric pneumatique à 2 étages à chariot
-  Gato neumático portátil de 2 etapas con carrito

J3C

-  Cric pneumatico portatile a 3 stadi con carrello
-  **Pneumatic 3-stage jack with trolley**
-  Pneumatischer Wagenheber mit 3 Stufen, mit Wagen
-  Cric pneumatique à 3 étages à chariot
-  Gato neumático portátil de 3 etapas con carrito

 Guida telescopica interna • Valvola di sicurezza • Dispositivo di arresto a fine corsa

 **Telescopic stabiliser • Safety valve • Stroke limiting device**





 Innere teleskopische Führung • Sicherheitsventil • Automatische Arretierung bei Maximalhöhe

 Guidage télescopique interne • Soupape de surpression • Dispositif d'arrêt à la hauteur maximale

 Guía telescópica interna • Válvula de seguridad • Dispositivo de paro en final de carrera

J2 - J3 | 2 t



 Dati tecnici	 Technical data	 Technische Eigenschaften	 Caractéristiques techniques	 Datos técnicos		J2P	J3P
						J2C	J3C
Portata	Capacity	Tragfähigkeit	Capacité	Capacidad de carga	t	2	2
Pressione lavoro	Working pressure	Hubdruck	Pression de travail	Presión de trabajo	bar	7	7
Corsa	Stroke	Hubhöhe	Course	Carrera	mm	165	190
Peso	Weight	Gewicht	Poids	Peso	Kg	14	16

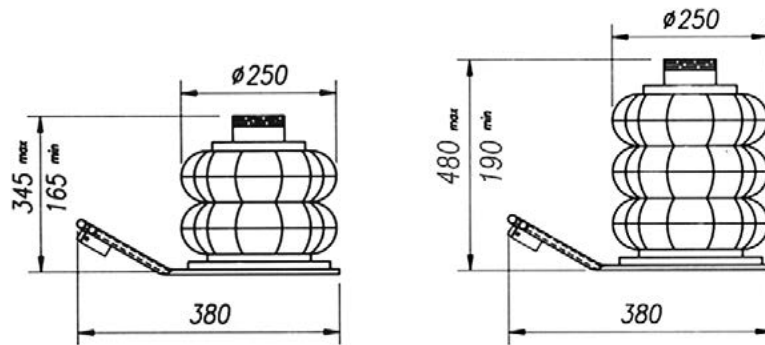

 Opzioni	 Optionals	 Sonderzubehör	 Options	 Opcionales
---	--	--	--	---

Prolunga 50mm
Extension 50mm
 Verlängerung 50mm
 Rallonge 50mm
 Prolongación 50mm

Prolunga 100 mm
Extension 100 mm
 Verlängerung 100 mm
 Rallonge 100 mm
 Prolongación 100mm