











RPK 25/B | 3,0 t



-  Sollevatore elettroidraulico con banco di raddrizzatura
-  **Electro-hydraulic lift with built-in pull bench**
-  Elektrohydraulische Hebebühne mit integrierter Zugwerkbank
-  Élévateur électrohydraulique avec banc de tirage incorporé
-  Elevador electro-hidráulico con banco de enderezamiento



-  Braccio di tiro fissabile in qualunque posizione intorno al banco • Braccio di tiro rotativo auto-orientabile • Altezza minima 100 mm • Centralina con comandi a 24V. tipo "uomo presente" e pulsantiera mobile a cavo • Sicurezze elettriche, idrauliche e meccaniche • Segnale acustico ultimo tratto di discesa
-  **Pull-arm can be fixed in any position around the bench • Auto-orienting rotating pull-arm • Min. height 100 mm • Control unit with commands at 24V "dead man" type and portable push button control panel with cable • Electric, hydraulic and mechanical safety units • 'Buzzer' on last portion of descent**
-  Zugarm um den Bank in irgendeiner Lage fixierbar • Schwenkbarer Zugarm mit automatischer Einstellung • Min. Höhe 100 mm • "Totmanschaltung"-Steuereinheit an 24V. und tragbarer Tastschalter • Elektrische, hydraulische und mechanische Sicherheiten • Akustisches Signal im letzten Teil der Senkbewegung
-  Bras de tirage fixable dans toute position autour du banc • Bras de tirage rotatif auto-orientable • Hauteur min. 100 mm • Pupitre avec commandes à 24V. type "homme mort" et boîte à boutons portable avec câble • Sûretés électriques, hydrauliques et mécaniques • Signal sonore sur la dernière partie de descente
-  Brazo de tiro fijable en cualquier posición alrededor del banco • Brazo de tiro giratorio auto-orientable • Altura mínima 100 mm • Centralita con mandos de 24 V tipo "hombre presente" y botonera móvil con cable • Seguridad eléctrica, hidráulica y mecánica • Señal acústica último tramo de descenso

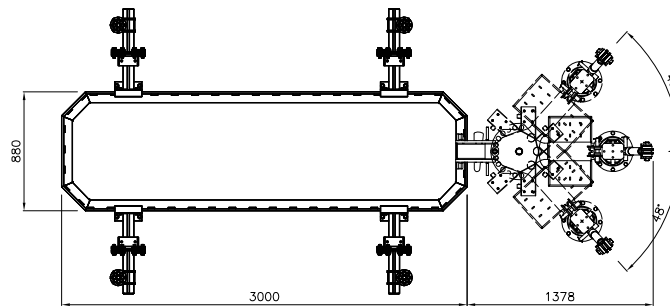
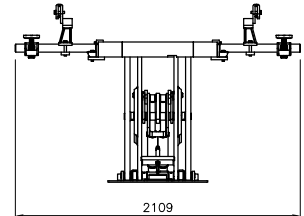
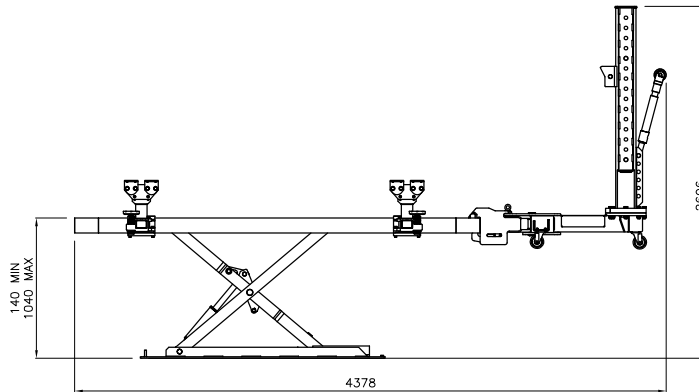

- 4 braccetti di sostegno con asta millimetrata di riferimento
- 4 tamponi di sollevamento a vite
- 4 morsettiere universali
- 4 cavalletti di appoggio
- 1 catena completa di gancio
- 1 morsetto universale
- 1 pompa pneumoidraulica

- 4 Stützarme mit mm-Einteilung
- 4 Aufnahmeteller mit Gewinde
- 4 Universalklemmhalter
- 4 Stützständer
- 1 Kette mit Haken
- 1 Universalklemme
- 1 pneumatische Hochdruckpumpe

- 4 brazos de soporte con vara milimetrada de referencia
- 4 tacos de elevación con rosca
- 4 pinzas universales
- 4 caballetes de apoyo
- 1 cadena completa de gancho
- 1 pinza universal
- 1 bomba neumo-hidráulica

- 4 supporting arms with graduated rod
- 4 lifting pads with screw
- 4 universal terminal boards
- 4 supporting stands
- 1 chain complete with hook
- 1 universal clamp
- 1 pneumo-hydraulic pump

- 4 bras de support avec tige millimétrée de référence
- 4 tampons de levage à vis
- 4 porte-mors universels
- 4 béquilles d'appui
- 1 chaîne complète de crochet
- 1 pince universelle
- 1 pompe pneumo-hydraulique



Dati tecnici

Technical data

Technische Eigenschaften

Caractéristiques techniques

Datos técnicos

Portata • Capacity • Tragfähigkeit • Capacité • Tragfähigkeit • Capacidad	3.000 kg
Altezza minima • Min. height • Min. Höhe • Hauteur min. • Altura mínima	140 mm
Altezza massima • Max. height • Max. Höhe • Hauteur max. • Altura máxima	1.040 mm
Lunghezza telaio • Frame length • Rahmenlänge • Longueur chassis • Longitud chasis	3.000 mm
Larghezza telaio • Frame length • Rahmenlänge • Longueur chassis • Ancho chasis	880 mm
Motore • Motor • Motorleistung • Puissance moteur • Motor	1,5 kW - 380V 50/60 Hz



Opzioni

Optionals

Sonderzubehör

Options

Opcionales

- Esecuzione monofase
- Single phase version
- Einphasige Ausführung
- Version monophasée
- Motor monofásico

L1276

- Rampe ausiliarie per vetture ribassate
- Auxiliary ramps for lowered cars
- Zusatzrampen für tiefgelegte Fahrzeuge
- Rampes auxiliaires pour voitures surbaissées
- Rampas auxiliares para vehiculos de perfil bajo